

PRODUCT TECHNICAL DATA SHEET

CARTRIDGE PA

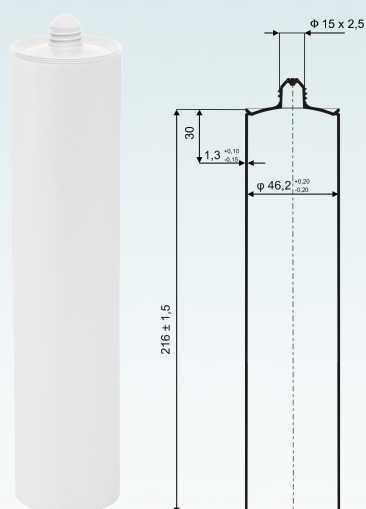

| | |
|-----------------------|----------------|
| Volume | 310 ml |
| Material | PA |
| Weight | 51 ± 1,5 g |
| Inner diameter | Ø46,2 ± 0,2 mm |
| Thread | 15 x 2,5 mm |
| Colors | white |
| Warranty | 12 months |

Palletization*

3360 / 3780 szt. - 140pcs. per box

*other variants to be discussed with Customer Office

Other aspects:

- packaging requires storage testing in the target use environment
- the customer is responsible for validating the packaging with the target batch

Compatible products

Plunger K-02, Plunger K-11
 Nozzle Clip DC10, Nozzle Standard D01, Nozzle Clip Cap VD17, Nozzle V-SEAM with clip, Nozzle VD17-PCR50B, Nozzle DC10-PCR50B

V.4 / 28/10/2025