

PRODUCT TECHNICAL DATA SHEET

CARTRIDGE PP32-HT

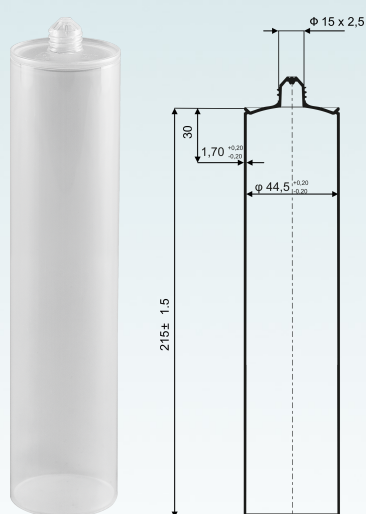

Volume	310 ml
Material	PP
Weight	38 ± 1,5 g
Inner diameter	Ø46,2 ± 0,2 mm
Thread	15 x 2,5 mm
Colors	highly transparent
Warranty	12 months

Palletization*

3360 / 3780 szt. - 140pcs. per box

*other variants to be discussed with Customer Office

Other aspects:

- packaging requires storage testing in the target use environment
- the customer is responsible for validating the packaging with the target batch

Compatible products

Plunger K-02
Nozzle Clip DC10, Nozzle V-SEAM with clip

V.1 / 23/10/2025