

PRODUCT TECHNICAL DATA SHEET

CARTRIDGE RG29-PCR50

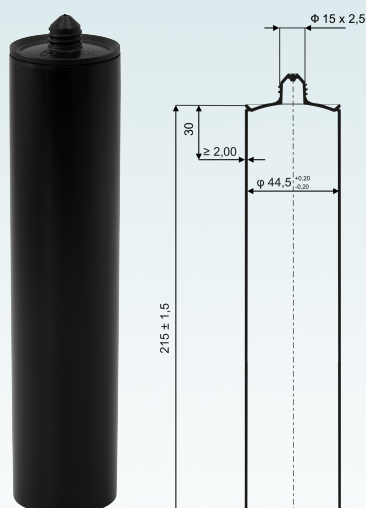

UV screen printing

Volume	290 ml
Material	PCR HDPE 50%, HDPE 50%
Weight	$69 \pm 1,5 / - 2,0$ g
Inner diameter	$\varnothing 44,5 \pm 0,2$ mm
Thread	15 x 2,5 mm
Colors	gray, black
Warranty	12 months

Palletization*

3360 / 3780 szt. - 140pcs. per box

*other variants to be discussed with Customer Office

Other aspects:

- packaging requires storage testing in the target use environment
- the customer is responsible for validating the packaging with the target batch

Compatible products

Nozzle Clip DC10, Nozzle V-SEAM with clip

V.4 / 28/10/2025